



Multi-Objective MDO Solution Strategy for Multidisciplinary Design using modeFRONTIER

**Sumeet Parashar and Nader Fateh
Esteco North America Inc.**

**April 16th 2007
IPDO 2007 – Miami Beach, FL**

- **Design of Complex Engineering Systems**
 - Involves Multiple Disciplines
 - Involves Multiple Objectives
- **Design/Optimization Methods**
 - Multidisciplinary Design Optimization (MDO)
 - Multi-Objective Pareto (MOO or MOP)

■ MDO Problems

- Coupled disciplinary interactions
- Couplings imply iteration (i.e. significant computational expense)

■ MOP

- No single optimum
- Set of optimum solutions called Pareto solutions

- How can we perform a multi-objective optimization for highly coupled MDO problems?
- How can multiple Pareto points be generated as efficiently as possible?
- How can we obtain the Pareto solutions for these MDO problems without having to do expensive system analysis too often?

■ Coupled MDO problem

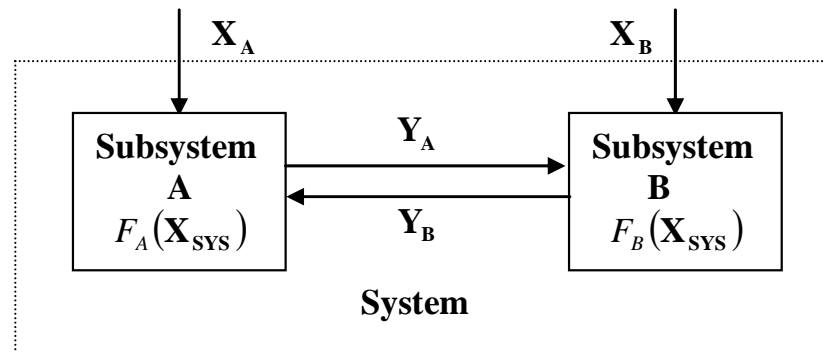

■ MDO formulations

- Single Objective
 - MDF, IDF, AAO, CO, CSSO, ATC ...
- Multi-Objective
 - MOCO, M-MGA, iMOODS, MOPCSSO ...

- **Proposed Iterative Multi-Objective Genetic Algorithm with Response Surface Approximation**
 - Genetic Algorithm (GA) based heuristic solution strategy for coupled MOP-MDO problems
 - Generate multiple Pareto designs in efficient and faster manner
 - Implement the proposed method using modeFRONTIER

■ MOGA – Advantages

- Generate multiple Pareto points fairly quickly
- Generate non-convex and discontinuous Pareto front
- No prior knowledge required
- Reasonably well-distributed and uniform Pareto front

- **Multi-Objective MDO with modeFRONTIER**
 - Use response surface approximation to reduce computational expense of system analysis
 - NSGA-II for multi-objective optimization
 - Iterative refinement of response surface and optimization until convergence

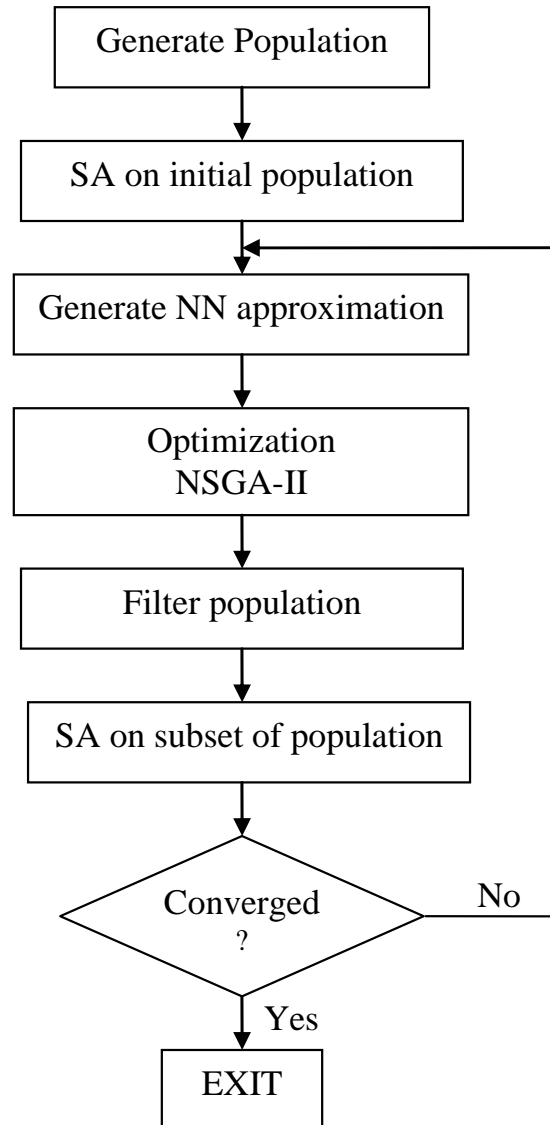

■ Step 1

- Generate initial population
- Random or DOE

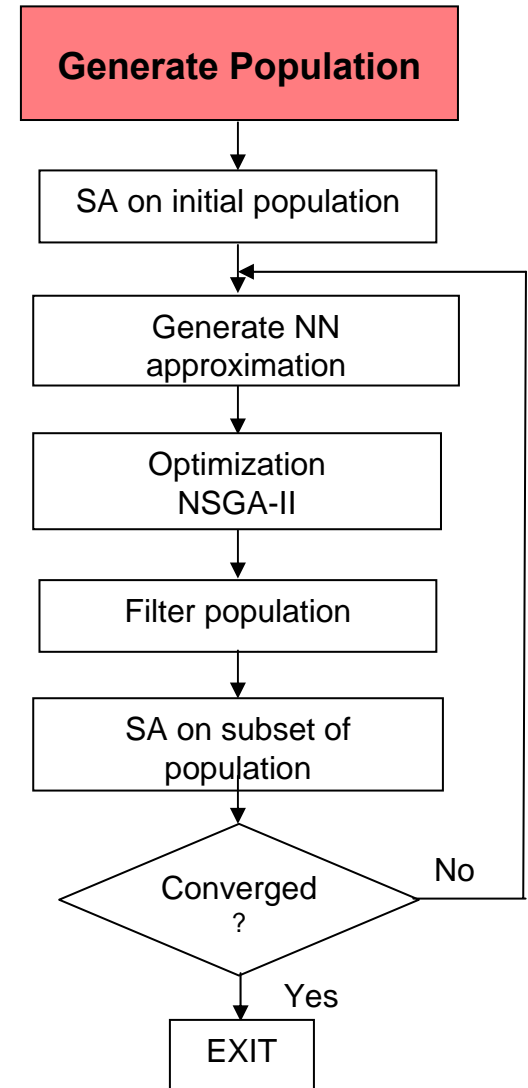

■ Step 1

- Generate initial population
- Random or DOE

■ Step 2

- System Analysis on initial population

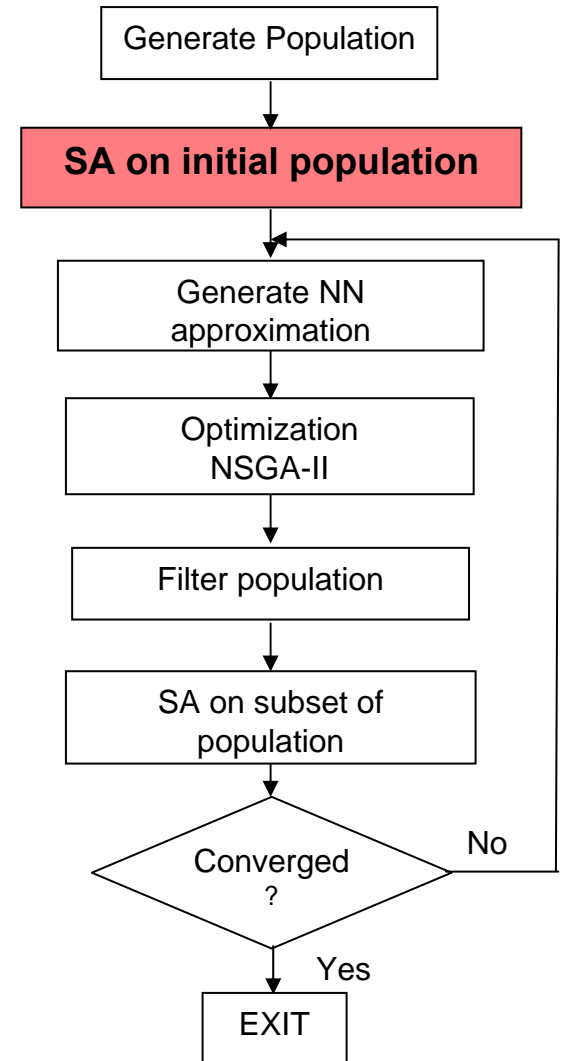

■ Step 1

- Generate initial population
- Random or DOE

■ Step 2

- System Analysis on initial population

■ Step 3

- Create response surface (Neural Network)
- X's input, F, g – output

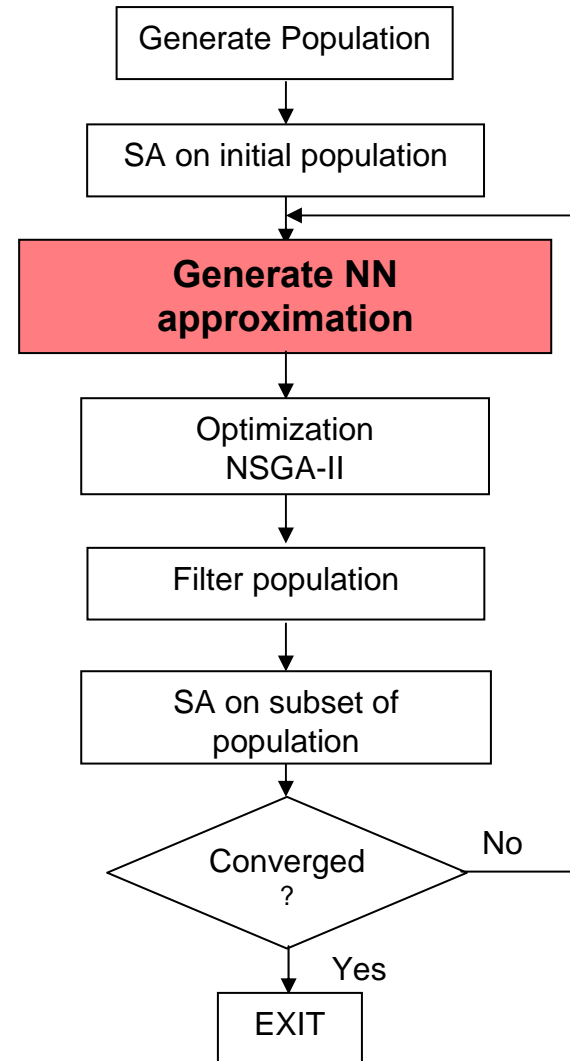

■ Step 4

- Multi-Objective Optimization (Non-Dominated Sorting Genetic Algorithm – NSGA-II)
- F and g's evaluated using response surface
- Fixed number of generations

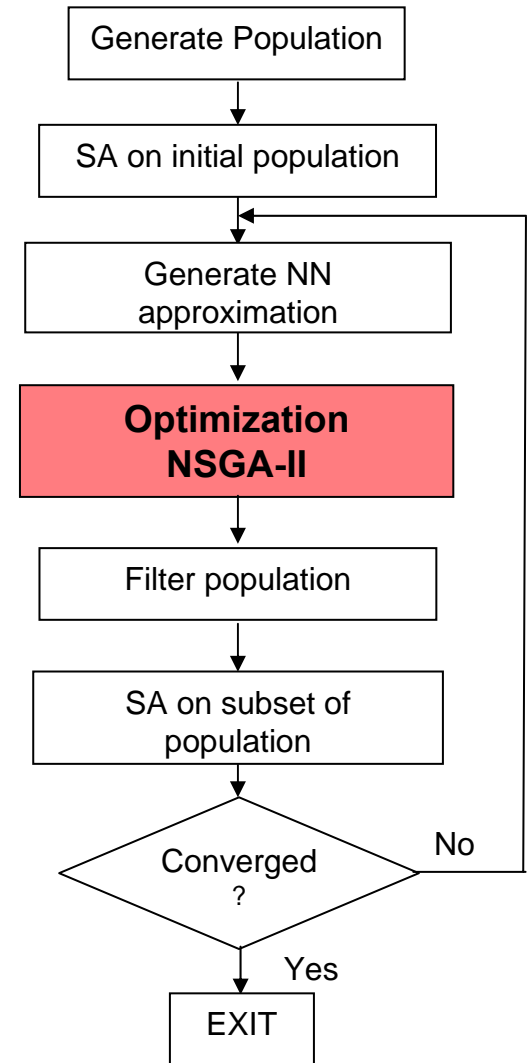

- **Step 5**
 - Filter Pareto and near Pareto designs

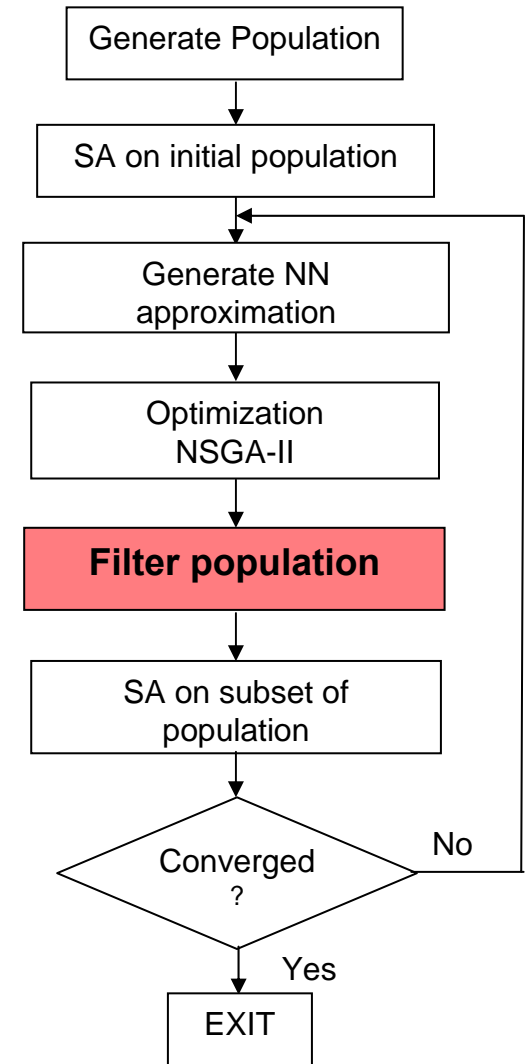

- **Step 5**
 - Filter Pareto and near Pareto designs
- **Step 6**
 - System Analysis on subset (filtered set) for real analysis

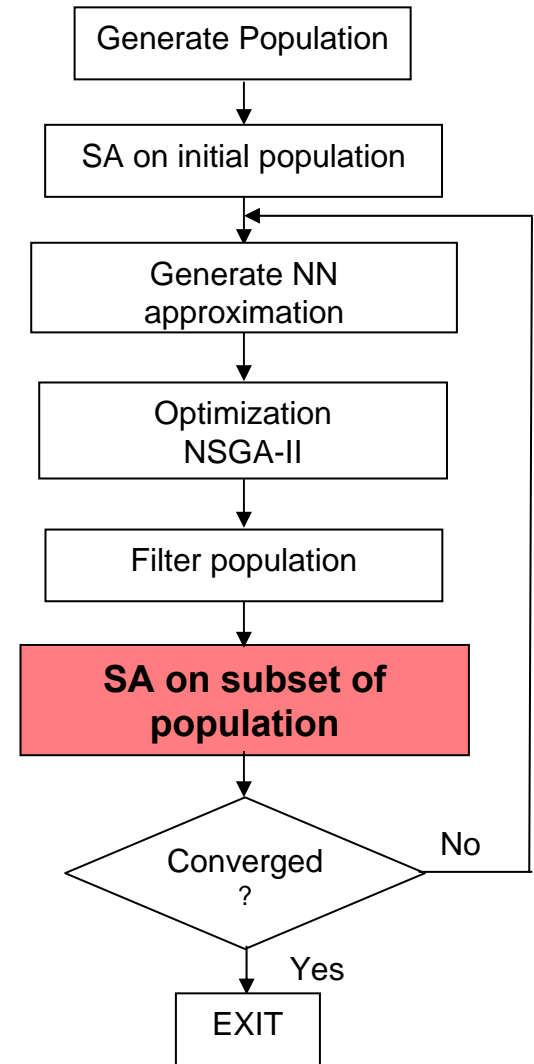

■ Step 5

- Filter Pareto and near Pareto designs

■ Step 6

- System Analysis on subset (filtered set) for real analysis

■ Step 7

- Convergence:
Check real and virtual values (of F's and g's) for Pareto designs

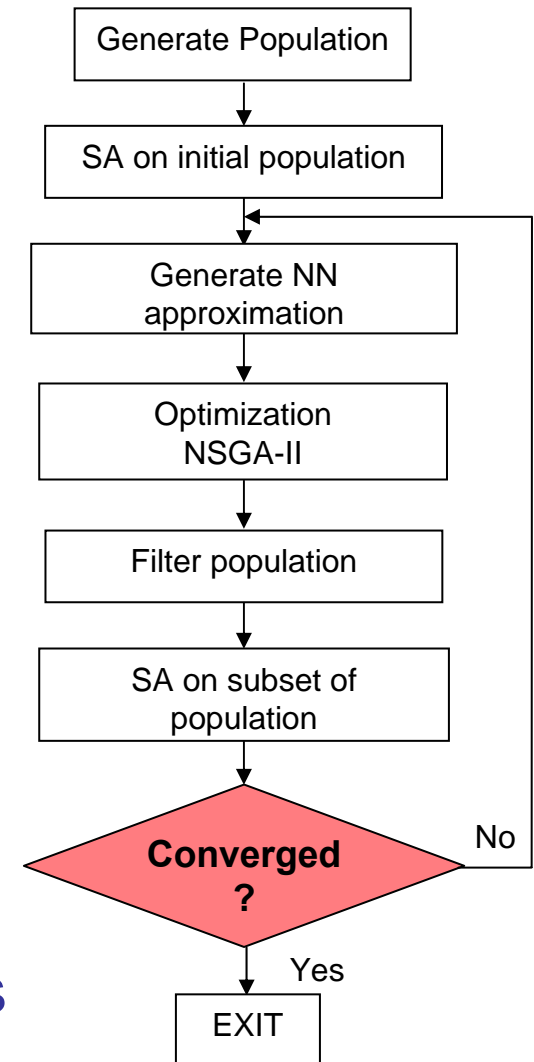

- **CASCADE generated test problem**

- **CASCADE –**

- Classified as generator of class 1 test problems by MDO Test Suite – NASA Langley Research Center
- Developed at University at Buffalo

- **Test problem**

- Two subsystems
- Bi - Objective

Test Problem

■ Test problem

- 10 design variables
- 2 Objective Functions
- 10 Constraints

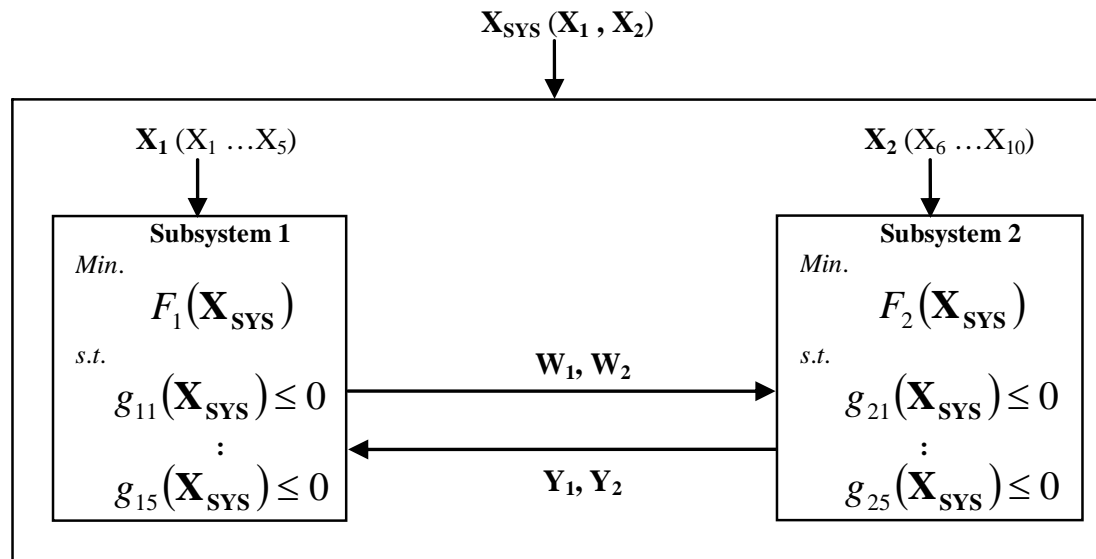

Test Problem

■ Pareto Front

- Generated by MOPCSSO using multiple starting points or setting range on objective

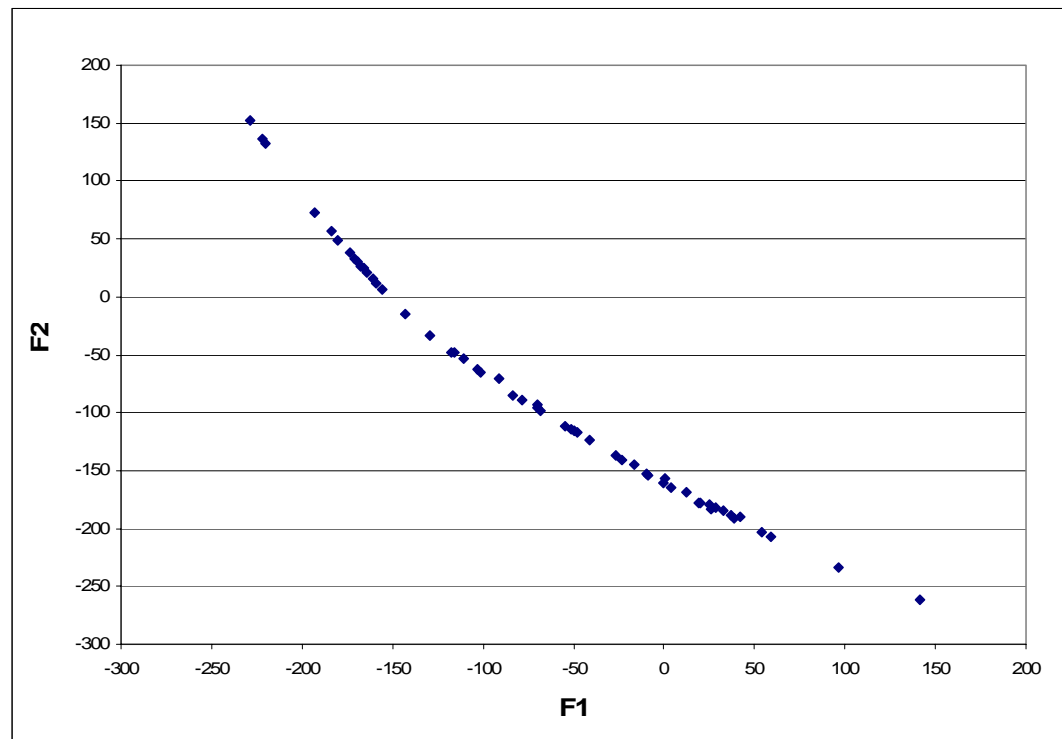

Test Problem

■ Problem setup in modeFRONTIER

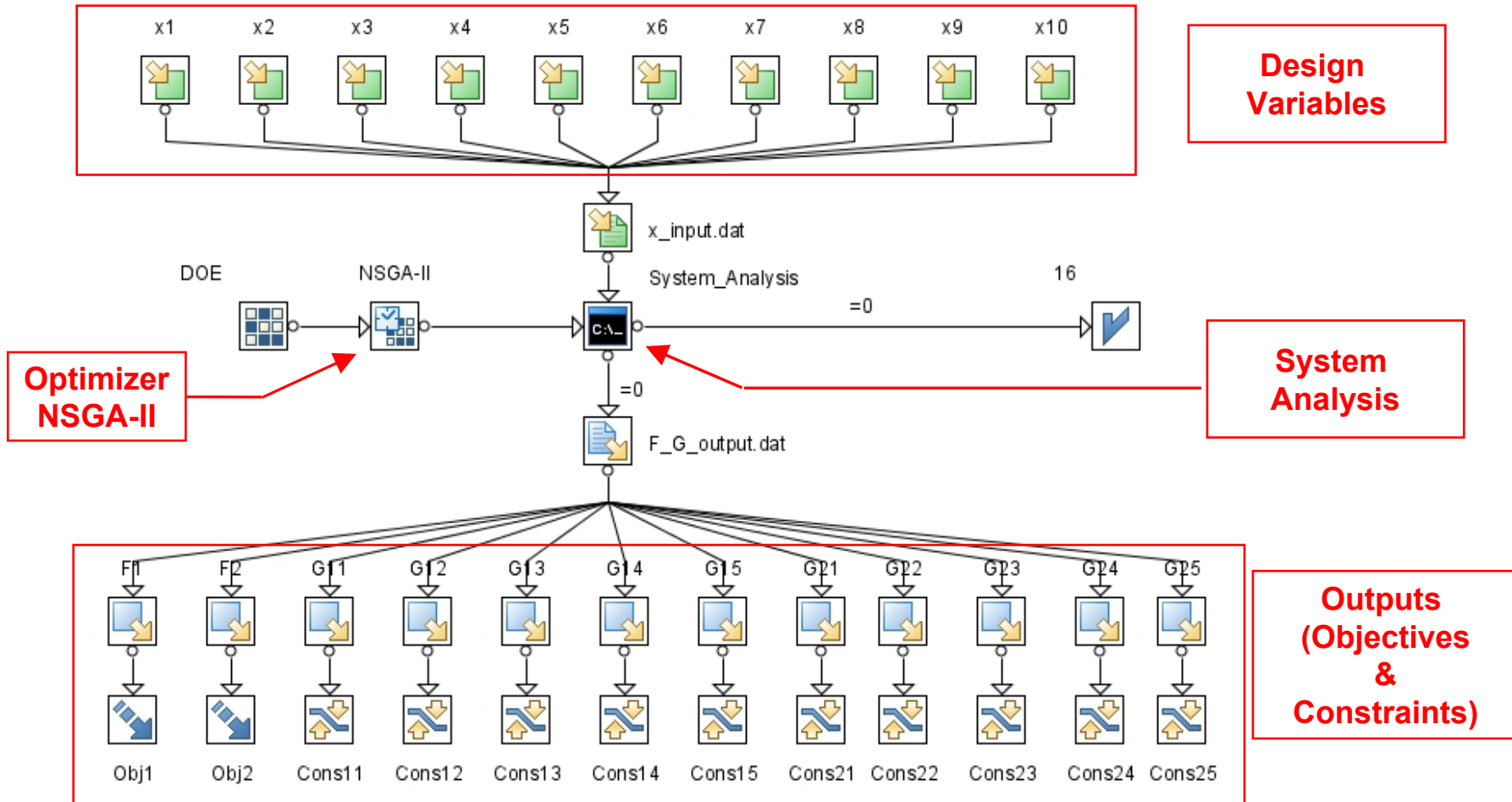

Test Problem

- **Problem parameters**

- **First cycle**

- Initial Population - 200

- # of generations for NSGA-II - 100

- **Further cycles**

- Smaller population

- Higher number of generations

Test Problem

■ Designs after 1st cycle (performance space)

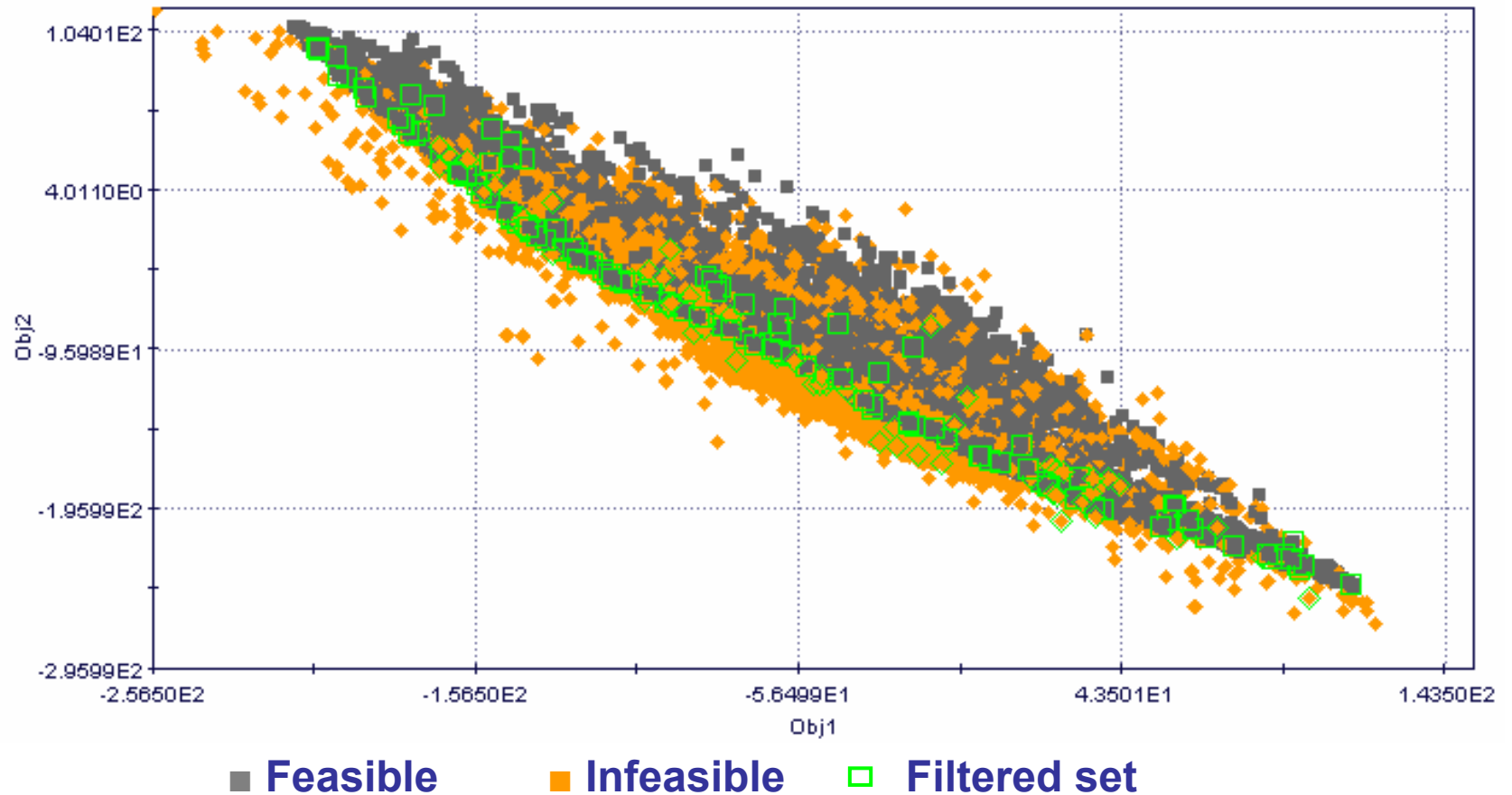

Test Problem

■ Convergence check after 1st cycle

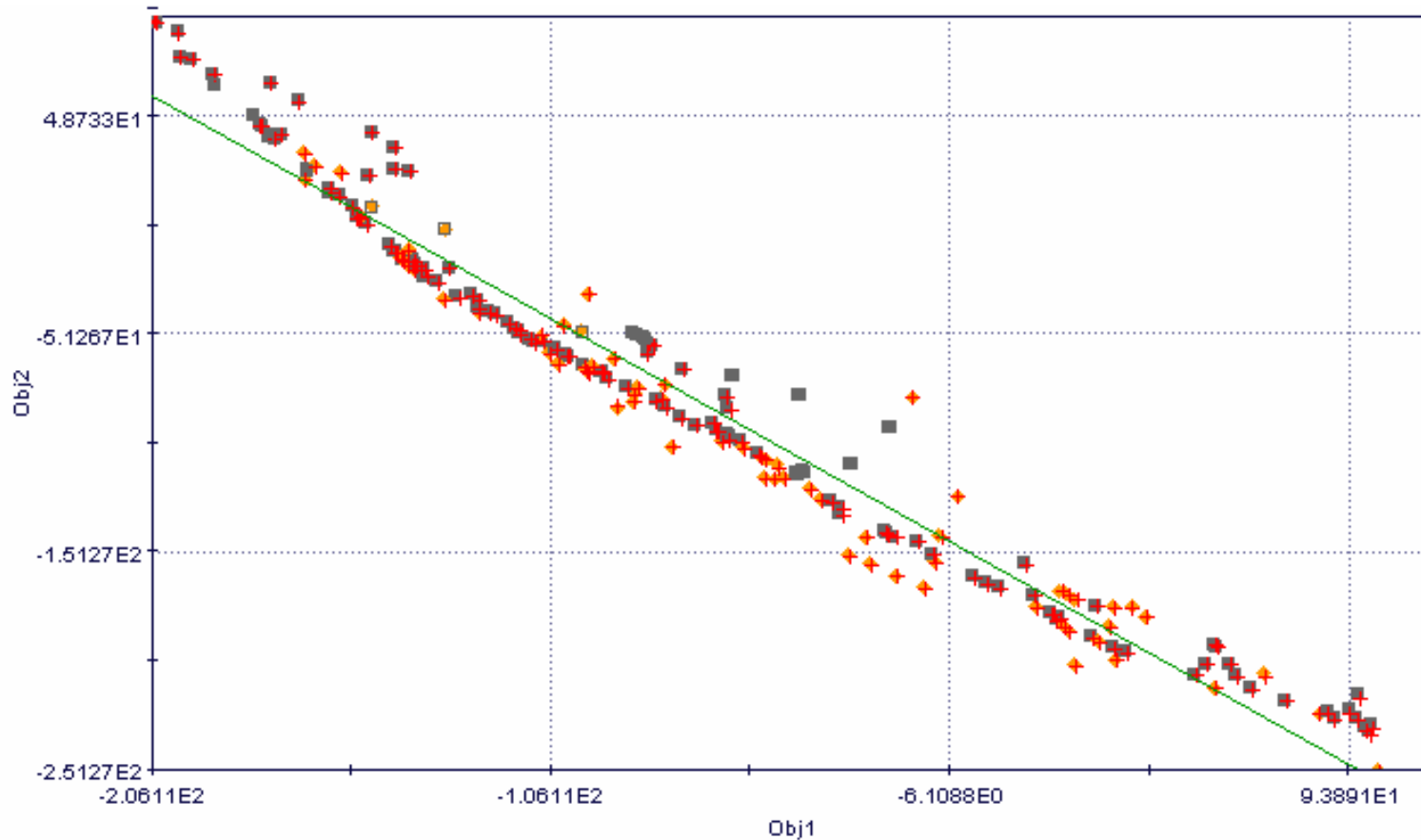

+ real and infeasible

Test Problem

■ Results after 4th cycle

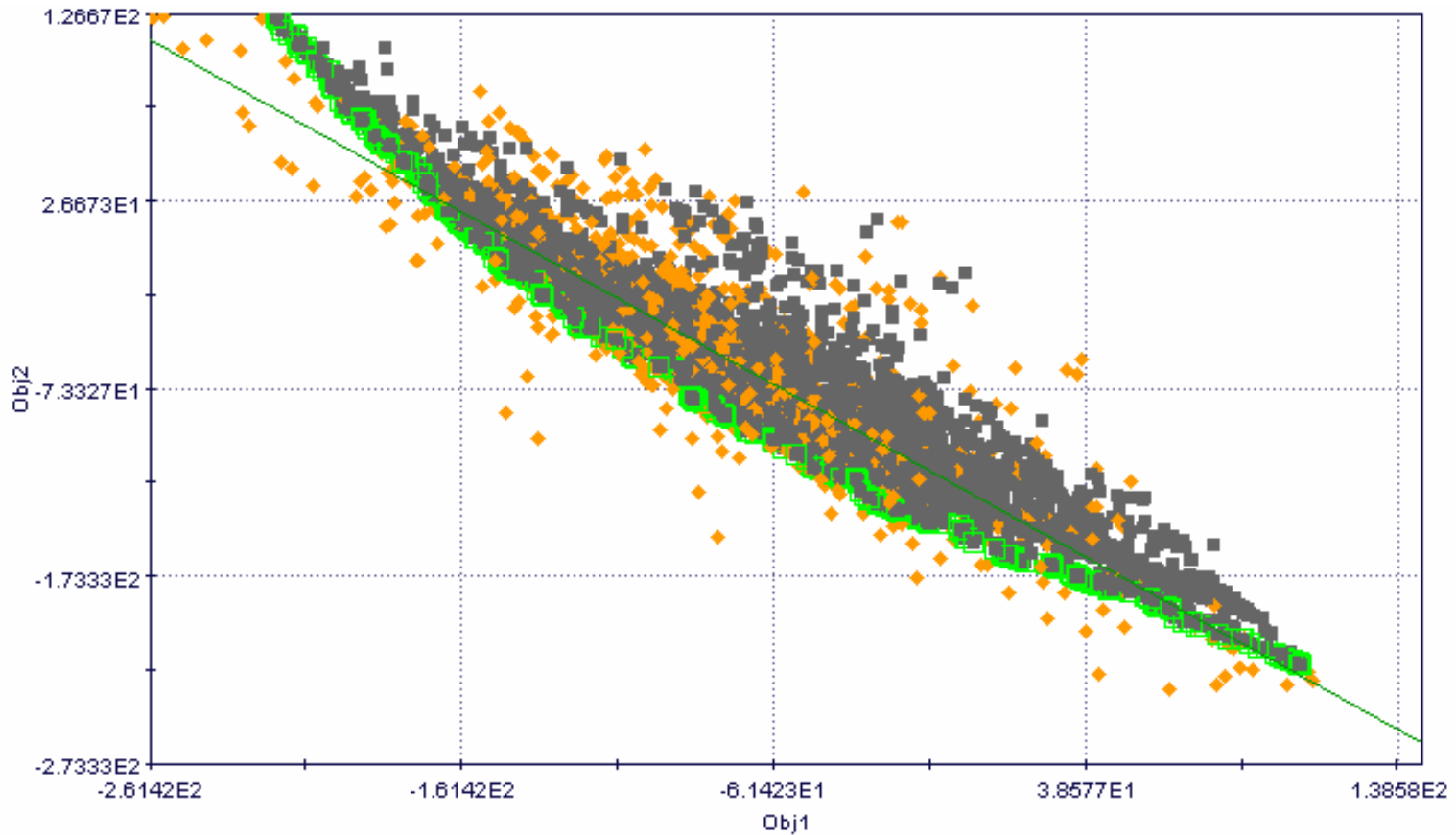

■ Feasible

■ Infeasible

□ Pareto designs

Test Problem

■ Results after 4th cycle

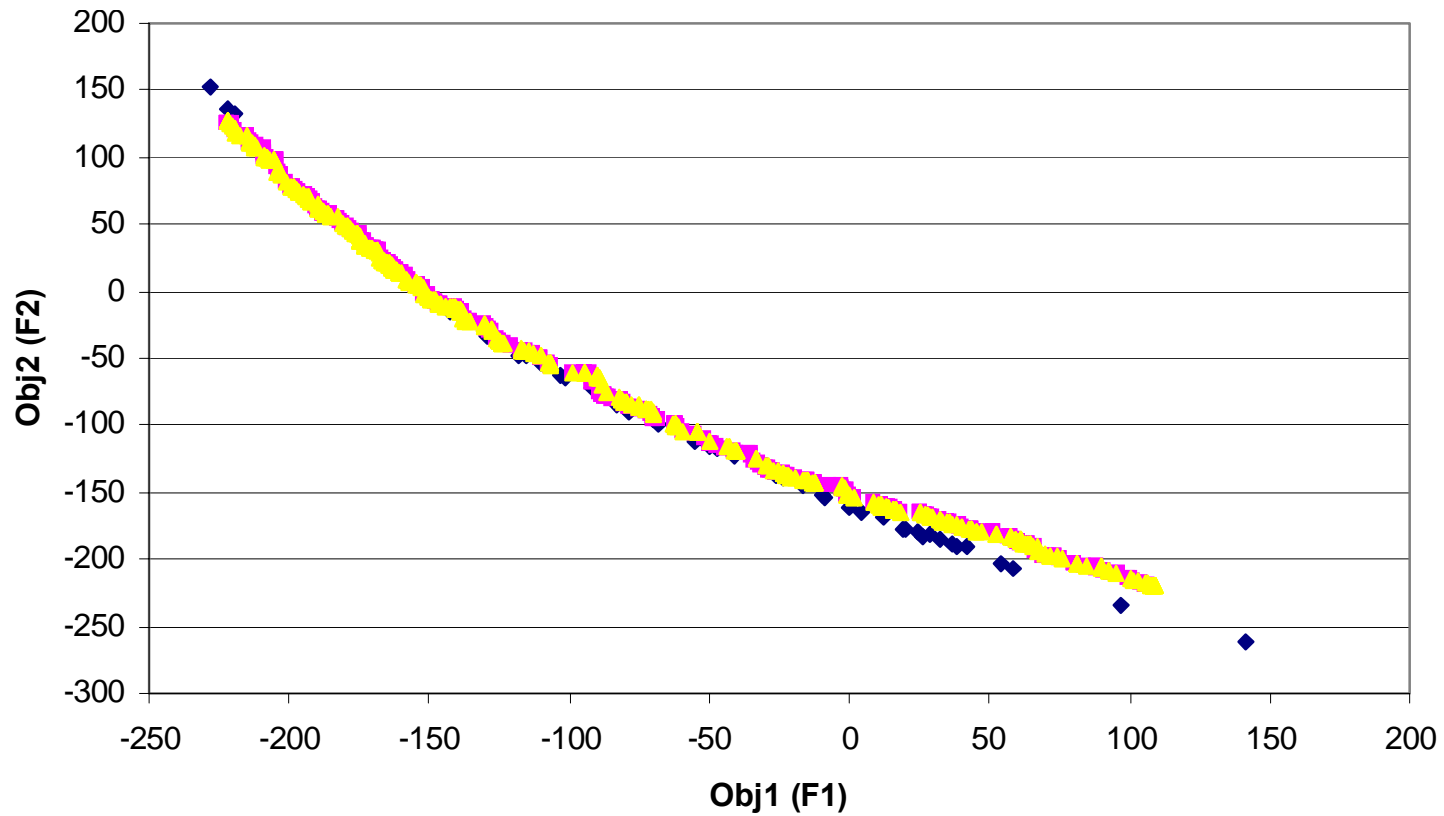

◆ MOPCSSO

◆ Virtual

◆ Real

Results Summary

■ MOPCSSO

- 20 – 40 cycles for one Pareto point
(depending on initial point)
- For 200 Pareto points, 4000 – 8000 system analysis
(SA) (function evaluations)

■ Proposed Method

- SA on approximately 200 points each cycle
(to train ANN)
- 4 cycles for convergence (200 or more Pareto points)
- 800 function evaluations
(efficient by order of magnitude)

Conclusions

- **GA-based heuristic strategy for coupled Multi-Objective MDO problems demonstrated to be feasible**
- **Neural Network approximations reduce computational expense of full system analysis**
- **Easy to setup and implement using modeFRONTIER**
- **Substantially efficient**



Thank you